

TECHNICAL REVIEW

No.1 — 1980

Contents

Luminance Contrast Measurement	
by O. Nielsen	3
News from the Factory	22

Luminance Contrast Measurement

by

Ole Nielsen

ABSTRACT

Important factors determining the suitability of an installation for lighting the interiors of offices and similar work places are the amount of light provided (luminance), and the ability of the installation to reproduce contrast. Visual tasks depend on the perception of contrast, but practical lighting installations tend to cause contrast reduction. Conventional methods of measuring contrast reduction are fairly time-consuming, and depend partly on human judgement. A method has been developed which is rapid, reproducible and independent of human factors. The method depends on the use of a passive Contrast Standard whose characteristics model those of typical printed matter, and whose design and manufacture are optimized for reproducibility and stability. An electronic meter designed to read contrast and contrast reduction directly has been developed for use in conjunction with the Contrast Standard.

SOMMAIRE

Les facteurs importants déterminant les qualités d'une installation d'éclairage d'un bureau ou d'un poste de travail similaire sont la quantité de lumière fournie (luminance) et l'aptitude de l'installation à reproduire le contraste. Les tâches visuelles dépendent de la perception du contraste, mais en pratique, les installations d'éclairage ont plutôt tendance à réduire le contraste. Les méthodes conventionnelles de mesure de réduction du contraste sont longues et partiellement subjectives. La méthode qui est présentée ici est rapide, reproductible et indépendante des facteurs humains. Elle repose sur l'utilisation d'un Contraste étalon passif dont les caractéristiques sont proches de celles d'un texte imprimé typique et dont la conception et la fabrication sont optimisées pour obtenir la meilleure reproductibilité et la meilleure stabilité. Un indicateur électronique a été conçu pour donner une lecture directe du contraste et de la réduction de contraste en utilisant le Contraste étalon.

ZUSAMMENFASSUNG

Die Eignung einer Beleuchtungsanlage für Büros und ähnliche Arbeitsplätze hängt haupt-

sächlich von zwei Faktoren ab — der vorhandenen Lichtmenge (d.h. der Leuchtdichte) und der Fähigkeit des Beleuchtungssystems Kontraste wiederzugeben. Die Deutlichkeit eines Sehobjekts hängt von seinem Kontrast ab, die meisten Beleuchtungssysteme neigen jedoch dazu, Kontrastminderungen hervorzurufen. Konventionelle Methoden zur Bestimmung der Kontrastminderung sind oft zeitraubend und basieren z.T. auf subjektiven Beurteilungen. Es wurde eine Methode zur schnellen und reproduzierbaren Bestimmung von Kontrastminderungen entwickelt, bei der keinerlei subjektive Faktoren eine Rolle spielen. Hierbei wird ein passives Kontrastnormal verwendet, dessen Kontrast dem einer typischen Drucksache entspricht. Durch sorgfältige Entwicklung und Fertigung wurde optimale Stabilität und Reproduzierbarkeit erreicht. Für die Verwendung in Verbindung mit dem Kontrastnormal wurde ein elektronisches Meßgerät entwickelt, welches Leuchtdichtekontrast und Kontrastminderung direkt anzeigt.

Introduction

In the field of luminance-contrast measurement, various methods are available for calculating the contrast rendering factor for a given lighting installation. The methods are often based upon the use of a visibility meter to reduce the contrast to the threshold value for human visibility, enabling the actual task visibility to be calculated.

In order to perform measurements which are independent of human factors, more quickly and safely, a new, direct method has been developed. This method depends on the measurement of the reflected luminance of standard surfaces whose reflectance characteristics have been prescribed over a wide range of incident — light and measurement directions. The method was devised by the Danish Illumination Engineering Laboratory [1], and correlates with the results of investigations made by J. Reitmaier [2] and W.L. Uitterhoeve/W. Keschull [3].

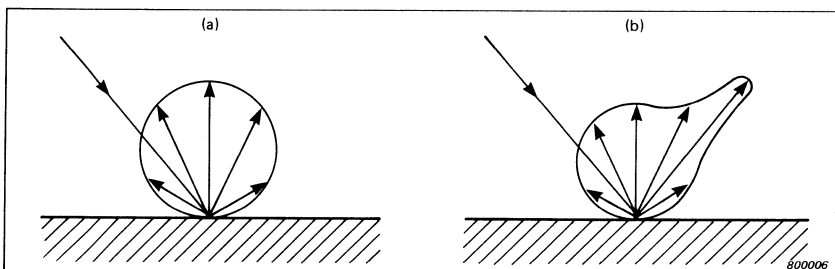

Fig.1. Graphical illustration of the way different kinds of surfaces reflect light

(a) Perfect diffuser

(b) Typical white paper

The two factors determining the level of visual performance attainable by subjects with achromatic tasks typical of office work are the luminance to which the subject is accustomed and the ease with which the task can be seen against its background. The first factor is determined by the illuminance of both the task and the background. The second factor is determined by the reflectance characteristics of the task and the background — characteristics which could be complicated. The documents used in most office functions reflect light by a combination of diffuse and specular mechanisms (see Fig.1). Close examination of a number of common office materials, e.g., pencil, ink and printed text, reveals a strong specular component at normal viewing angles. Because of this specular element, the contrast of such common visual tasks as pencilled text on matt paper will be determined partly by the distribution of incident light in relation to the subject's viewing position. An illustration of the variation which can occur in the contrast of a single task as a result of differing incident-light distributions is shown in Fig.2.

The specular component of reflection from a piece of paper is enhanced by the act of writing or printing on it, partly because the surface features are smoothed out and partly because new material is added. The effect is to reduce the contrast. In some cases it may disappear or even change sign.

This reduction in contrast leads to a corresponding reduction in visual performance. How this happens is described thoroughly in CIE Technical Report 19, [4], and a later edition of the same report (under preparation).

It is not possible to equate visual performance with the more diffuse expression "visual comfort". It is hardly surprising that there are fundamental differences between the two quantities. General observations indicate that working in lighting conditions which produce veiling reflections in visual tasks is very unpleasant, even if the contrast is great enough for clarity. Human experience of how good the lighting could be here play an important role.

The investigations carried out by Uitterhoeve and Kepschull [3] showed that the quality of a lighting system and the comfort of subjects working with visual tasks illuminated by it are dependent on the reduction in contrast, irrespective of whether the tasks themselves are of high or low contrast.

Solafskærmning

Princippet i en solafskærmning er at man stræber efter at udelukke og tillade lyset at komme ind i rummet. Da ca. halvdelen af varmen i solafskærmningen netop befinder sig i det synlige område af solspektret, må man

Solafskærmning

Princippet i en solafskærmning er at man stræber efter at udelukke og tillade lyset at komme ind i rummet. Da ca. halvdelen af varmen i solafskærmningen netop befinder sig i det synlige område af solspektret, må man

Fig.2. Photograph of the same document in different lighting conditions, illustrating the variation in contrast possible

The Contrast Standard

The basic idea behind the method for determining the quality of lighting systems is to set up a performance criterion by measuring the contrast between a pair of prescribed light and dark reference surfaces.

For work involving materials with relatively large specular components, as for example in libraries and some offices, the contrast reduction should be as small as possible and should not exceed 15% within the working area.

For work involving materials having relatively small specular components, as for example in classrooms and some offices, the contrast reduction should be as small as possible and should not exceed 30% within the working area.

A portable standard embodying accurately prepared samples of the prescribed light and dark reference surfaces has been developed (Fig.3). It is designated Luminance Contrast Standard Type 1104, and forms a detachable part of Luminance Contrast Meter Type 1100.

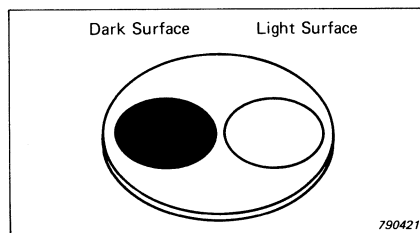

Fig.3. The Luminance Contrast Standard Type 1104

The contrast value for the reference standard at a working point in any lighting system can be determined from measurements of the reflected luminance made with the light and dark surfaces located successively at the working point. Integration over the required range of incident light directions is inherent in the exposure of each surface to light incident from the entire illuminating hemisphere. The contrast value C is defined by the equation

$$C = \frac{L_2 - L_1}{L_1} \times 100\% \quad (1)$$

where L_1 is the background luminance (light) and L_2 the target lumi-

nance (dark). (In the Type 1100 this calculation is executed automatically and C displayed as a positive number.) The measurement of reflected luminance is made on an axis coincident with the normal viewing direction, since the contrast values for other directions (which are likely to be different for many kinds of lighting systems) are of no interest.

As explained above, the contrast aspect of visual comfort which is correlated best is the contrast reduction, R. R is normalized to the maximum attainable contrast C_{max} (which is used to define a reference lighting system). R is given by the equation

$$R = 1 - \frac{C}{C_{max}} \quad (2)$$

$$R = \left(1 - \frac{C}{C_{max}}\right) \times 100\% \quad (3)$$

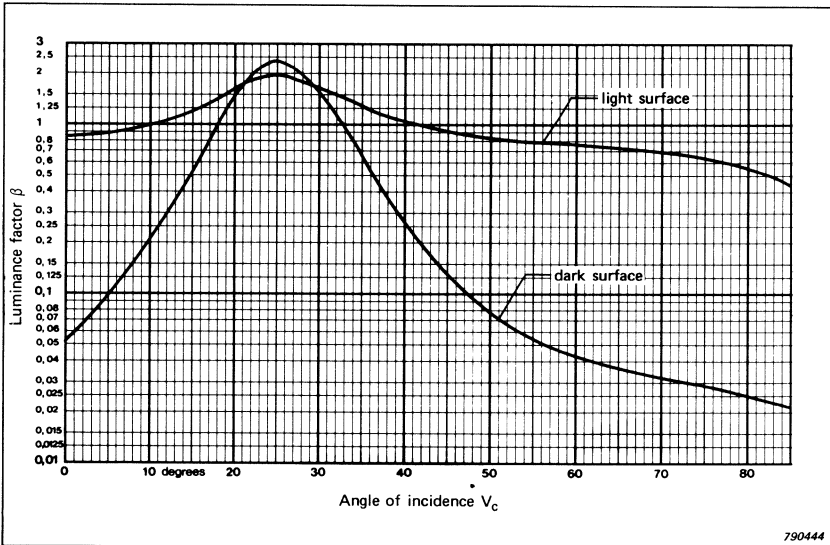

Fig. 4. Luminance factors for the light and dark reflectance surfaces of the Luminance Contrast Standard, plotted as functions of the angle made by the incident light with the normal to the surfaces. The measurement direction makes an angle of 25° with the normal and lies in the plane containing the incident light and the normal

The luminance factors obtained for the light and dark surfaces with a range of incident-light and measurement directions are set out in tables. The luminance factor β of a surface is defined as the ratio L/L_D , where L is the measured luminance, and L_D is the luminance obtained by substituting a perfectly diffuse, perfectly reflecting surface for the surface to be measured. A graphical plot of these factors for one specific situation where the plane containing the incident-light and measurement directions is normal to the surfaces is given in Fig.4.

Where the incident-light and measurement directions make equal angles with the normal to the surfaces, the specular component of reflection is large. Reference to equation (1) shows that, for incident-light angles close to the measurement angle, the contrast changes sign (see Fig.5). At angles remote from this, the contrast is high and changes very little with changing direction. The variation in dark surface luminance with illuminance direction is very marked compared with that for the light surface. Note that the luminance-factor scale is logarithmic.

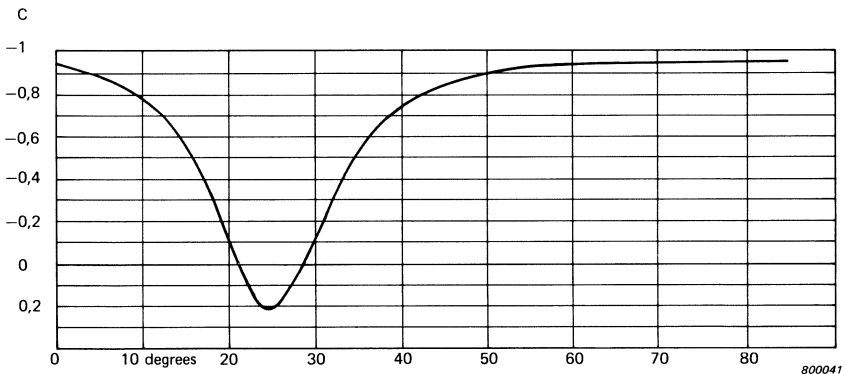

Fig.5. Contrast, C , of the Luminance Contrast Standard, plotted as a function of the angle made by the incident light with the normal to the surfaces. The measurement direction is as with Fig.4.

Construction of the Standard

Basic requirements of any standard are stability of the parameters standardized and immunity to environmental influences. In the case of a contrast standard it is essential therefore that the materials used be in-

organic. Several possible compositions were investigated before a suitable choice could be made. The optimum composition for the standard surfaces was found to consist of ceramics and glass. The light surface has a glass layer silk-screen printed directly on a ceramic substrate, by a method similar to that used in the preparation of thick-film electronic circuits. The relief mask used in this process produces a surface structure which changes under the action of temperature. The characteristics which the surface has when it sets are determined by controlling the time-and-temperature profile of the hardening stage. When the light surface is used for measurement, light is reflected from both the surface-structure elements and the ceramic substrate, and the measured luminance is the sum of the two.

The dark surface is designed so that reflection from the substrate does not occur. A non-reflective layer is interposed between the glass and the substrate. This layer is a combination of glass and metal particles capable of absorbing most of the light passing through it. To prevent reflections from the boundary between this absorbent layer and the one above it, their refractive indices are matched. Almost all the light reflected by the dark surface is therefore reflected at the surface itself, whose structure is controlled in the same way as that of the light surface. However, there is also a small proportion of diffuse reflection obtained from the body of the non-reflective layer.

In the case of pure surface reflections from non-metallic substances, the luminance factor is a function of the distribution of orientations of infinitesimal surface elements taken over the entire measuring area. For any specified angle of incident-light and measurement direction, the luminance factor may be calculated provided this distribution is known. The method is described in Ref.[5]. The validity of the calculations are limited by two factors. First, neither incident nor measurement angle must be so great that occultation between surface elements occurs. Secondly, the surface elements must be much larger than the wavelength of light.

The Luminance Contrast Meter

For making fast, straightforward measurements with the luminance contrast standard, an instrument has been designed which coordinates the measurement geometry, measures the reflected luminance and performs the calculations (Fig.6). The Luminance Contrast Meter Type 1100 consists of a small cabinet, housing most of the controls, the power supply and the electronic circuitry, which includes a solid state

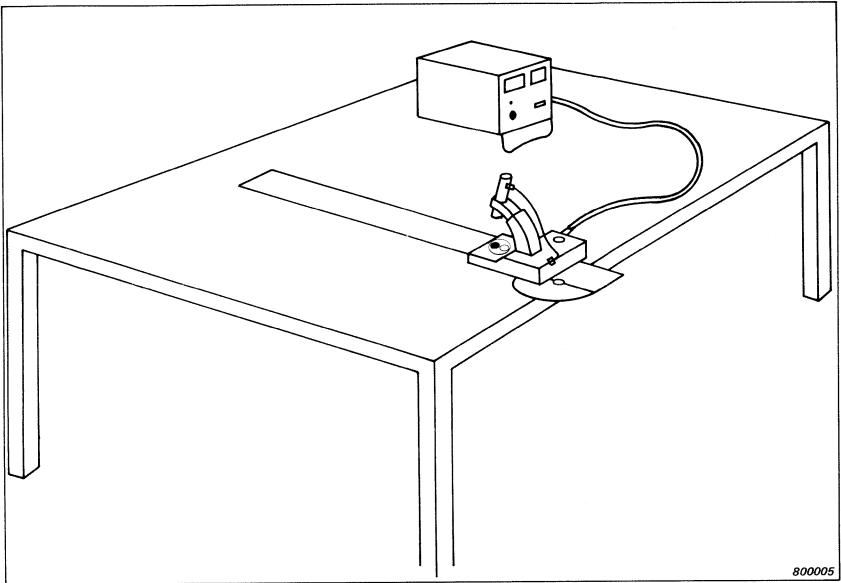

Fig.6. The Luminance Contrast Meter Type 1100 in use for measuring contrast on a working surface

display. For normal use, the meter is connected to accessories via a light-weight flexible cable. These accessories include a photoelectric measuring cell, which may be mounted on a carriage. The carriage also locates the Luminance Contrast Standard, and may be used on or off a graduated radius arm. This arm pivots about an integral protractor. The assembly is shown in Fig.7.

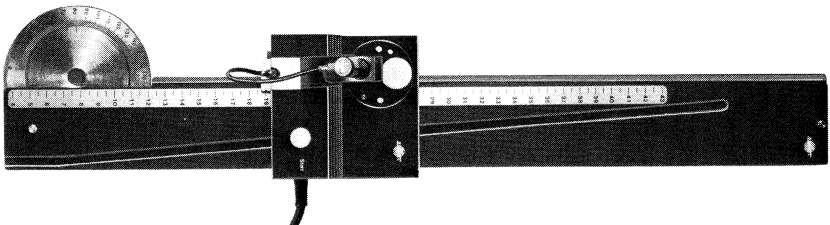

Fig.7. The measuring cell, goniometer, carriage, radius arm and protractor of the Luminance Contrast Meter

The protractor is provided with two lugs which enable it to be located positively on the edge of a desk, with the 0°-to-180° line lying along the desk edge. The pivot of the radius arm then defines the origin of a polar coordinate system to which the subsequent measurements are referred. This origin is taken to lie below the nominal eye point of a person working at the desk. The graduations on the protractor scale enable the bearing angle to be read off in degrees.

The radius arm has a graduated scale on which the distance of the measuring field from the origin may be read off. Machined in the radius arm is a skewed groove engaged by a pin on the carriage. As the carriage is moved along the radius arm the pin is constrained to follow this groove, and thereby moves across the carriage.

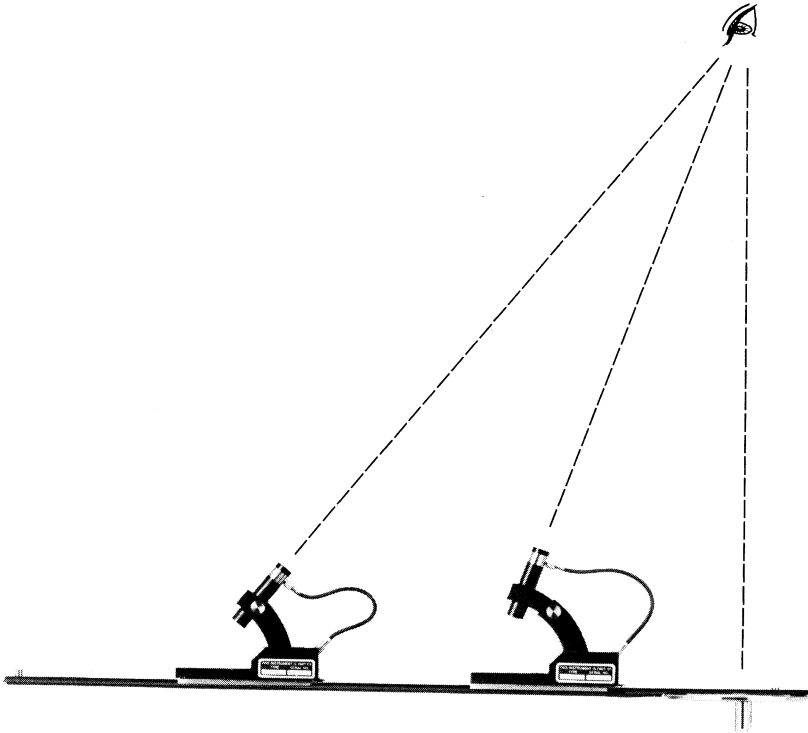

Fig.8. Illustration of the functioning of the eye-point following mechanism of the goniometer

The pin is coupled by a non-linear linkage to a goniometer, on which the measuring cell is mounted. The goniometer directs the measuring cell axis through the centre of the measuring field, regardless of the elevation of this axis. The nonlinear linkage ensures that as the carriage is moved, the elevation changes so that the measuring cell axis (projected back from the cell) always passes through the nominal eye-point (Fig.8).

The carriage incorporates a motorized turntable on which the Luminance Contrast Standard may be mounted. This turntable is used to bring each reflectance surface on the standard in turn into coincidence with the measuring field. Movement of the turntable is synchronized with the measurement and calculation routine of the instrument.

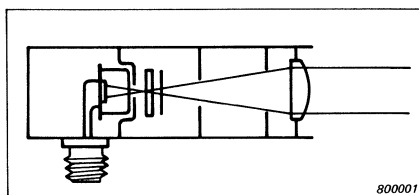

Fig.9. Construction of the measuring cell

The measuring cell (Fig.9) is an optical system containing a photoelectric receptor, filters and a lens. The receptor is a solid-state silicon type and has a large dynamic range. It is connected into the measuring circuit as a current source, which ensures excellent linearity of the transfer characteristic throughout this range. The current is proportional to the specific luminous power (measured in W/m^2). The selection of filters (Kodak gelatin 102 and Schott glass BG 38) combined with the spectral response characteristic of the receptor ensures that the current is also proportional to the visible input measured in cd/m^2 (Fig.10). The overall spectral response conforms to the 1931 CIE Photopic Curve within a tolerance of $\pm 10\%$ of the maximum sensitivity. The acceptance angle V of the measuring cell is determined by the focal length of the lens and the size of a circular aperture stop in the focal plane:

$$V = \tan^{-1} \left(\frac{r}{f} \right) \quad (4)$$

The diameter of the measuring field is determined by both the acceptance angle of the measuring cell and the diameter of the lens, as can be seen from Fig.11.

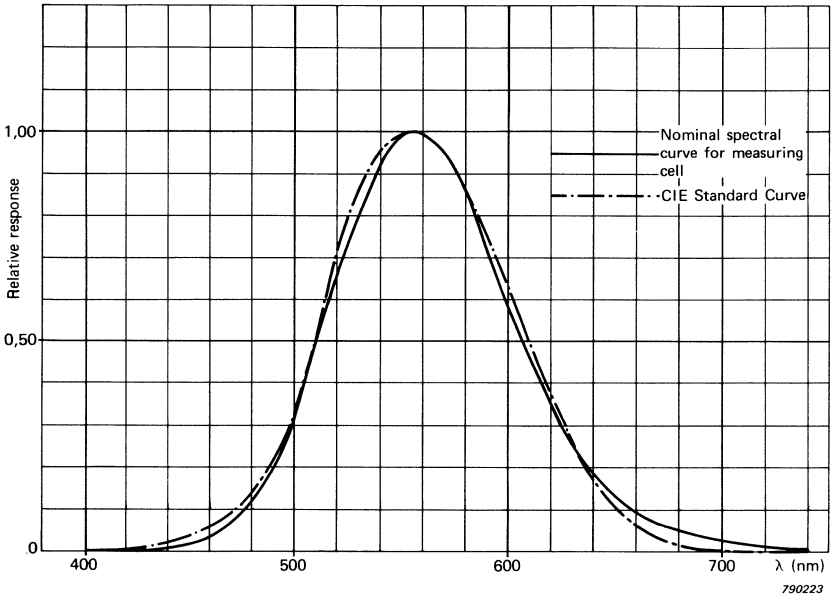

Fig.10. The spectral response of the measuring cell

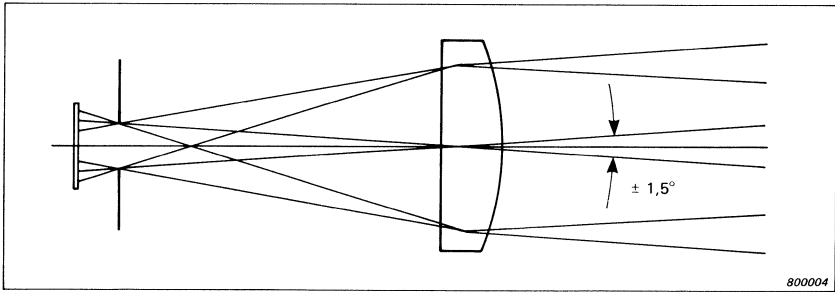

Fig.11. Acceptance geometry of the measuring cell

In the electronic circuitry the small current from the measuring cell is amplified by a high-performance transresistance amplifier (Fig.12). To avoid the need for the operator to set a current-balance potentiometer to cancel out the drift of the low-level amplifying stages, automatic zero-balancing takes place before every contrast calculation, and every 0,4 s when the instrument is used for luminance measurements.

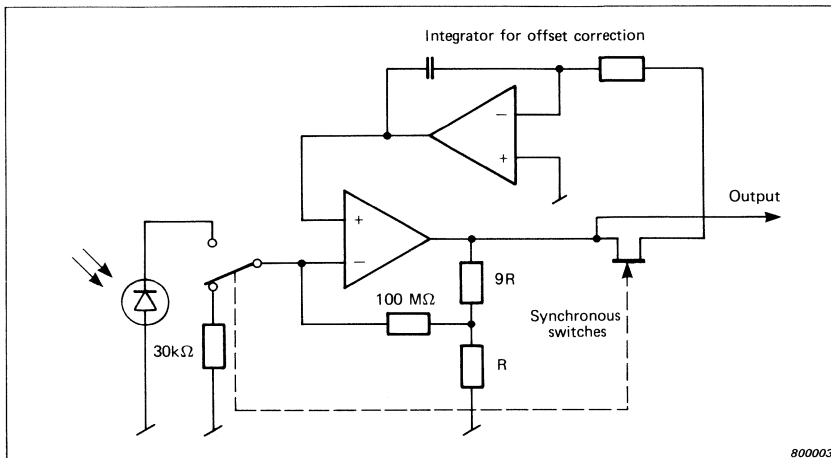

Fig.12. Simplified diagram of the electronic circuit used to amplify the current in the measuring cell

This provision prevents errors caused by drift even if the instrument is exposed to changing ambient temperatures. The automatic offset correction is remembered during the measurement by an electronic integrator.

The amplifier, whose output is available on a coaxial socket for connection to external instrumentation if required, has a transresistance of 1 mV/pA .

The current from the measuring cell is averaged over a 200 ms time-aperture. 200 ms has been chosen carefully, for compatibility with lighting systems powered by both 50 Hz and 60 Hz mains. It is equal to an integral number of cycles at both frequencies, so in each case a whole number of periods is averaged. If this were not the case, the measured luminance would depend on the timing of the measurement aperture relative to the phase of the mains supply, owing to the flicker of lighting systems powered by the mains. See Table 1.

A duty-cycle of 1:1000 in the measured luminance can be accommodated by the circuitry at full-scale indication, provided the repetition frequency is not too low. Correctly averaged measurements can therefore be made on the screens of visual display units (VDUs), which have relatively strong flicker.

	Frequency (Hz)	Period (s)	No. of complete cycles in one 0,2-s aperture
Mains supply frequency	50	1/50	10
	60	1/60	12
Lamp flicker frequency	100	1/100	20
	120	1/120	24

Table 1. Relationship between measurement aperture-time and AC mains frequency

Application of the Method

It has been found that people handling paperwork use a range of viewing angles centred at about 25° to the vertical. 85% of such activities are conducted with viewing angles between 0° and 40°, with greater angles occurring only for occasional glances. For an eye position 400 mm above the desk edge, the area of desk surface in which the contrast reduction is considered pertinent corresponds to a document of DIN A3 size (Fig.13). The goniometer and radius arm are designed to accommodate measurements to this format.

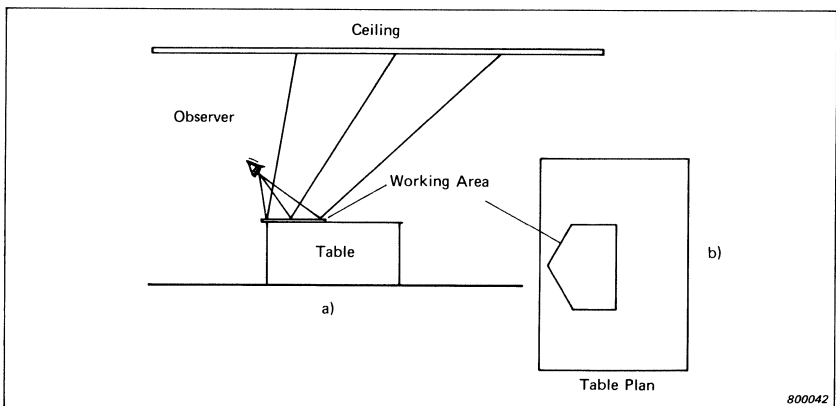

*Fig.13. Illustration of the configuration of the working area referred to for contrast measurements
(a) Elevation
(b) Plan*

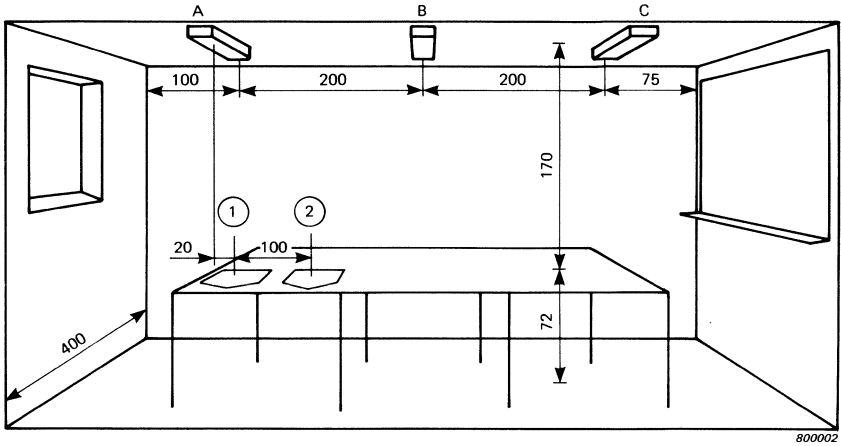

Fig.14. The arrangement of the conference room discussed in the example

Luminance contrast in working situations depends very much on how the observer is positioned in relation to lighting fixtures and reflections from walls and ceilings. The worst possible lighting situation occurs with a highly concentrated, elevated luminance source in the offending zone, with a high proportion of its light output directed at the visual task. An example of this is described below and illustrated in Fig.14.

In a small conference room, three light fittings are mounted directly on the ceiling. People can sit at different places around the table. Two such places are selected, and the contrast reduction R (equation 3 above) is charted for each. C_{max} is in this case the maximum attainable value of the Luminance Contrast Standard, 98%; but other reference values may be dialled into the Luminance Contrast Meter. In position 1 (Fig.15) a concentrated light from fitting A causes a large contrast reduction on a fairly large, crucial part of the working area. R values have been mapped for every intersection point on the mapping chart QP 4590, and contour lines for equal contrast reductions of 15%, 30% and 50% drawn. This result characterizes a poor lighting situation. Contrast reduction not exceeding 15% is recommended for working situations involving glossy documents in offices and schools.

In position 2 the situation is improved. There is no light-fitting directly in front of the observer, so the contrast reduction is small in the centre of the working area. Specular reflections caused by fittings A and B, which reduce the contrast, occur only at large angular devia-

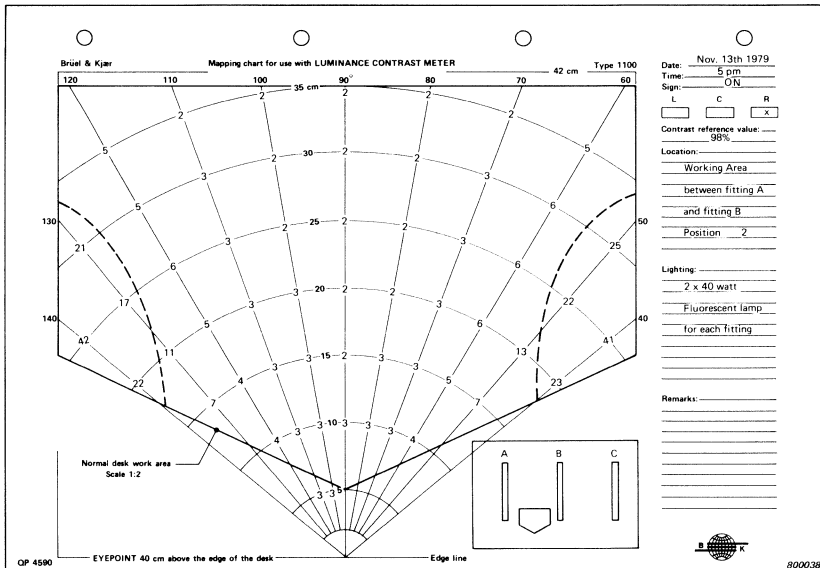
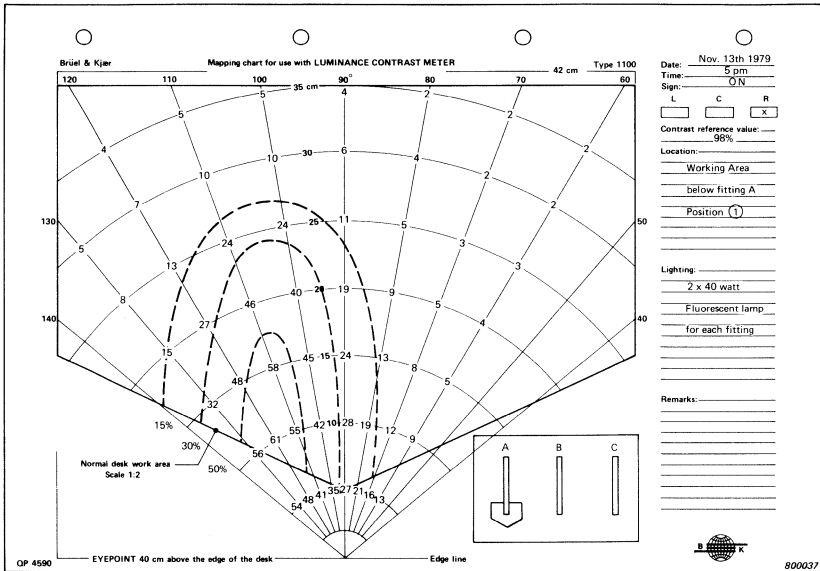

Fig.15. Contrast reduction charted on mapping paper QP 4590 for two working positions in the example
 (a) Position 1 (b) Position 2

tions from the centre. Over the complete working area the mean contrast is high. The situation at position 1 may be improved by adding an extra light source to the left of the person sitting there. A 40-watt incandescent lamp with a white plastic shield was placed 300 mm above the table. The effect of this addition was to improve the maximum contrast reduction from 61% to 45%.

Contrast is one of the factors influencing comfort and visibility. It is important for work involving flat tasks, such as documents containing text and illustrations. Hitherto defining and measuring these factors has been difficult. Now new possibilities have been opened up for working with light.

References

- [1] BJØRSET, H.-H., and FREDRIKSEN, G.: *"A proposal for recommendations for the limitation of the contrast reduction in office lighting"*. Paper read at the 1979 CIE Session in Kyoto, Japan, and reprinted as a B & K Application Note
- [2] REITMAIER, J.: *"Untersuchungen über Glanz und Lichtreflexe"*, Dr-Ing. dissertation, Fridericiana Karlsruhe University, 1977
- [3] UITTERHOEVE, W.L. and KEBSCHULL, W.: *Sehleistung und Sehkomfort im Büro*, Zweiter Euro päischer Lichtkongress (1973)
- [4] CEI TECHNICAL REPORT *"A unified framework of methods for evaluating visual performance aspects of lighting"*, CIE Technical Report No.19, 1972
- [5] RINDORF, H.J.: *"Luminance Reflectances — Explanation and calculation of contrast"*. B & K Application Note

Appendix

Photometric Quantities and Units

Luminous Flux

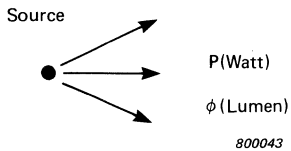

A light source emits power P (Watts).

A part of this power lies within the visible spectrum, 380 nm to 780 nm, and is measured in units of ϕ (lumens).

Luminous Intensity

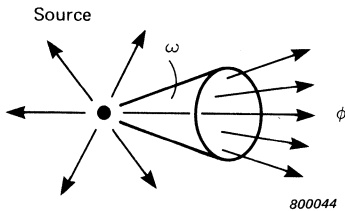

If the flux ϕ (lumens) in a given direction is linked in a small solid angle, ω (steradians), the light intensity I (candelas) in that direction is given by:

$$I \text{ (candelas)} = \frac{\phi \text{ (lumens)}}{\omega \text{ (steradians)}}$$

It may be deduced from the formula that the luminous flux per steradian from a source whose luminous intensity is 1 candela is 1 lumen.

Illuminance

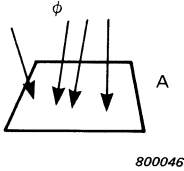
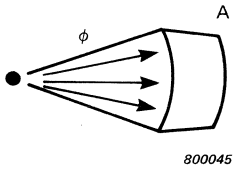

When the luminous flux ϕ enters a small area of surface A , the illuminance at that surface is

$$E \text{ (lux)} = \frac{\phi \text{ (lumens)}}{A \text{ (m}^2\text{)}}$$

Luminance

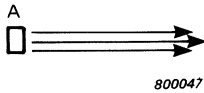

Luminance, formerly called brightness,

$$L \text{ (nit)} = \frac{I \text{ (candelas)}}{A \text{ (m}^2\text{)}}$$

is the luminous intensity per unit projected area, normal to the line of observation.

Conversion Factors

SI units	Footcandle (fc)	Footlambert (fL)	Sq. foot
1 lux (lm/m ²) =	0,0929		
1 nit (cd/m ²) =		0,292	
1 m ² =			10,76

News from the Factory

Luminance Contrast Meter Type 1100 and Luminance Contrast Standard Type 1104

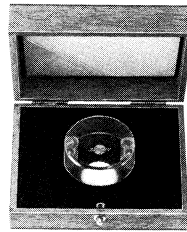
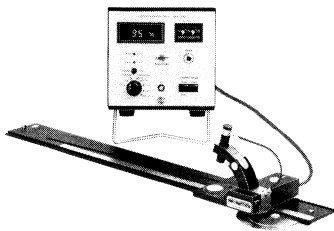

The Luminance Contrast Meter Type 1100 is a battery-powered luminance measuring instrument with a built-in calculating facility giving a direct reading of the contrast (C), contrast reduction (R) or ratio (L_2/L_1) of two successive luminance measurements L_1 and L_2 (see main article). It is intended for objective reference comparison of the contrast rendering ability of lighting systems. It may also be used as a high-performance luminance meter.

Its detachable measuring cell, which has a $\pm 1,5^\circ$ acceptance angle and a spectral response conforming to the CIE 1931 Photopic Curve, may be mounted on a goniometer attached to a carriage for recording the variation in C or R with viewing angle. For measuring the variation across an A3-sized area of desk-top, the carriage is used with a radius arm graduated in polar coordinates. A precision linkage mechanism keeps the goniometer automatically aligned with the nominal eye position of a person seated at the desk.

The results of such measurements may be plotted manually on special chart paper provided, or semi-automatically on normal perforated recording paper with Portable Level Recorder Type 2306.

The measuring cell may also be fitted into a sighting mount for measurements of visual task contrast, luminance and luminance ratios.

The Type 1100 reads out the quantity selected on a 2-1/2-digit LED display, which includes a memory. The contrast range available is -100% to $+100\%$, and the ranges of contrast reduction and luminance ratio are -199% to $+199\%$. There are five decade luminance ranges, $0 - 20 \text{ cd/m}^2$ to $0 - 200 \text{ kcd/m}^2$, enabling luminance to be measured down to $0,1 \text{ cd/m}^2$. The range may be selected automatically or manually.

The Type 1100 automatically adjusts its own zero point every 0,4 s. The measuring cell has a very rapid response to changing luminance. The linear average luminance during a digitally-controlled 0,2 s time-window is computed and used for the display or contrast calculations. It is also available as an analog voltage for connection to a recorder, statistical analyzer or remote meter. Pulsed light sources of very low duty cycle are correctly averaged.

Contrast measurement of lighting systems with the 1100 requires the use of a suitable contrast standard. This may be mounted on a motorized, self-parking turntable, which forms part of the carriage carrying the goniometer. The turntable enables the two reference surfaces of the standard to be positioned automatically, in sequence, in the field of view of the measuring cell. Two contrast standard blanks are provided for mounting the user's choice of reference surfaces.

However, for contrast measurement of lighting systems in offices, libraries and classrooms, the Luminance Contrast Standard Type 1104 should be mounted on the turntable. The reference surfaces of the 1104 have been specially developed to simulate the characteristics of typical documents used in offices. They are composed entirely of inorganic materials to ensure high stability, and manufactured under closely-controlled conditions for maximum reproducibility. The reflection characteristics of each surface are determined by the combined optical properties of the ceramic substrate and imprinted glass layers having a surface relief pattern. An individual calibration chart is supplied.

Each reference surface is 19 mm diameter. The surfaces are mounted 180° apart on the same face of a 40 mm blackened aluminium disc, which is provided with fixing holes and magnetic catches for easy attachment to the turntable of the 1100 or any alternative experimental apparatus.

The maximum attainable contrast is typically 98%. The chromatic contrast is negligible, both the x and y CIE trichromatic coordinates being 0,32 for the light surface and 0,31 for the dark surface, measured using illuminant C.

Audio Test Station Type 2116

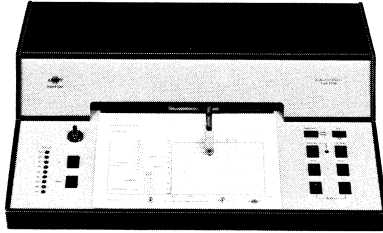

The Audio Test Station Type 2116, which combines a signal generator, frequency analyzer and a pen recorder, into a single desk-top unit, is designed with special emphasis on simplicity of operation, and clear, easy to interpret presentation of results. Frequency response, harmonic distortion (2nd and 3rd order), and intermodulation distortion (2nd and 3rd order) can all be measured automatically. Although primarily intended for measurements on hearing aids in accordance with IEC 118 and ANSI S3.22-1976, and on small microphones, using the Anechoic Test Chamber Type 4222, the Audio Test Station may also be used with Artificial Ears Types 4152 and 4153 for testing telephone or headphone earpieces, and with the Artificial Mastoid Type 4930 for measurements on bone vibrators.

The Frequency range is from 100 Hz to 10 kHz, covered in 256 discrete frequency steps at 1,8% increments. The generator section has a dynamic range of 40 dB in steps of 5 dB, selectable via pushkeys on the left of the front panel. Two oscillators are incorporated in the generator section. Only one of these is used to supply the single tone necessary for frequency response and harmonic distortion measurements, while for intermodulation distortion measurements, the outputs of both oscillators are summed to give the required double tone test signal. In this mode of operation the relative spacing of the two test tones is maintained automatically as the frequency range is swept.

The analyzer section has a total dynamic range of 100 dB and includes autoranging amplifiers to maintain the best possible dynamic range. On

selection of a particular measurement parameter, the logic circuit tunes the analyzer to the required frequency, e.g. the fundamental for a frequency response, or twice the fundamental for second harmonic distortion.

Results are plotted as the test proceeds on a pre-printed chart which is mounted on an angled chart bed for visibility throughout the measurement and ease of replacement. Before measurement begins the chosen test level and measurement parameters are indicated on the chart.

A special feature of the Type 2116 is the digital memory in which the frequency characteristics of the test environment (e.g. the Anechoic Test Chamber Type 4222) can be stored before measurements are made. During the test run, the level in the test chamber is then maintained at a constant level by continuous reference to this stored correction curve, making the use of a live compressor loop superfluous. Constant voltage output is also available.

A logic circuit connects and controls all the functions of the instrument, making it fully automatic and easy to operate after just a short period of familiarisation. Extensive use of switchmounted LEDs continuously indicate the chosen test parameters and the current status of the measurement.

Anechoic Test Chamber Type 4222

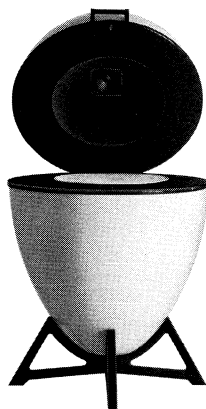

The Anechoic Test Chamber Type 4222 is a small anechoic chamber

with a built-in loudspeaker designed for frequency response and distortion measurements on hearing aids, and on small microphones. The special shape and design provide well-defined uniform acoustic test conditions within the chamber, as well as a high degree of insulation from external noise. Both these requirements are important for obtaining accurate and repeatable results.

The loudspeaker is especially designed for its excellent frequency response and dynamic range with very low distortion. Total harmonic distortion, at less than 0,5% at 80 dB SPL, meets the IEC R118 and the ANSI S3.22—1976 requirements for equipment for the specification of hearing aid characteristics. The frequency response of the chamber is flat to within ± 6 dB over its 100 Hz to 10 kHz frequency range, (even without correction), with uniformity over the measuring plane better than $\pm 2,5$ dB.

Extensive use of sound absorbent materials eliminates undesired reflections in the chamber and provides free-field conditions above approximately 400 Hz, allowing velocity as well as pressure sensitive microphones to be measured.

A suitable test signal can be supplied to the loudspeaker, which is mounted in the upper, openable section of the chamber from, for example, the Audio Test Station Type 2116, Sine Generator Type 1023 or Sine Random Generator Type 1027. Constant sound pressure level conditions may be maintained at the test plane either using the pre-recorded correction curve technique as in the Type 2116 Audio Test Station, or by using a second microphone in a compressor loop.